

REVISION HISTORY				
REV	ECN	DESCRIPTION	DATE	APPROVED
A	F050014	RELEASE PRINT	3/9/2005	dmjohnson
B	F110172	REDRAWN INVENTOR, ADD SHEETS 2-4	10/27/2011	dmjohnson
C	F110241	ADD MOTOR INFO NOTES & MOTOR W/O SWITCH CUTAWAY VIEWS	11/9/2011	dmjohnson
D	F120088	ADD SHEET 5: VS BTM FAN	10/24/2012	dmjohnson
E	F130069	1 HP DRIVE MOTOR WAS 3/4 HP	5/7/2013	dmjohnson
F	F180059	ADDED SHEETS 6, 7, & 8	7/13/2018	samelching

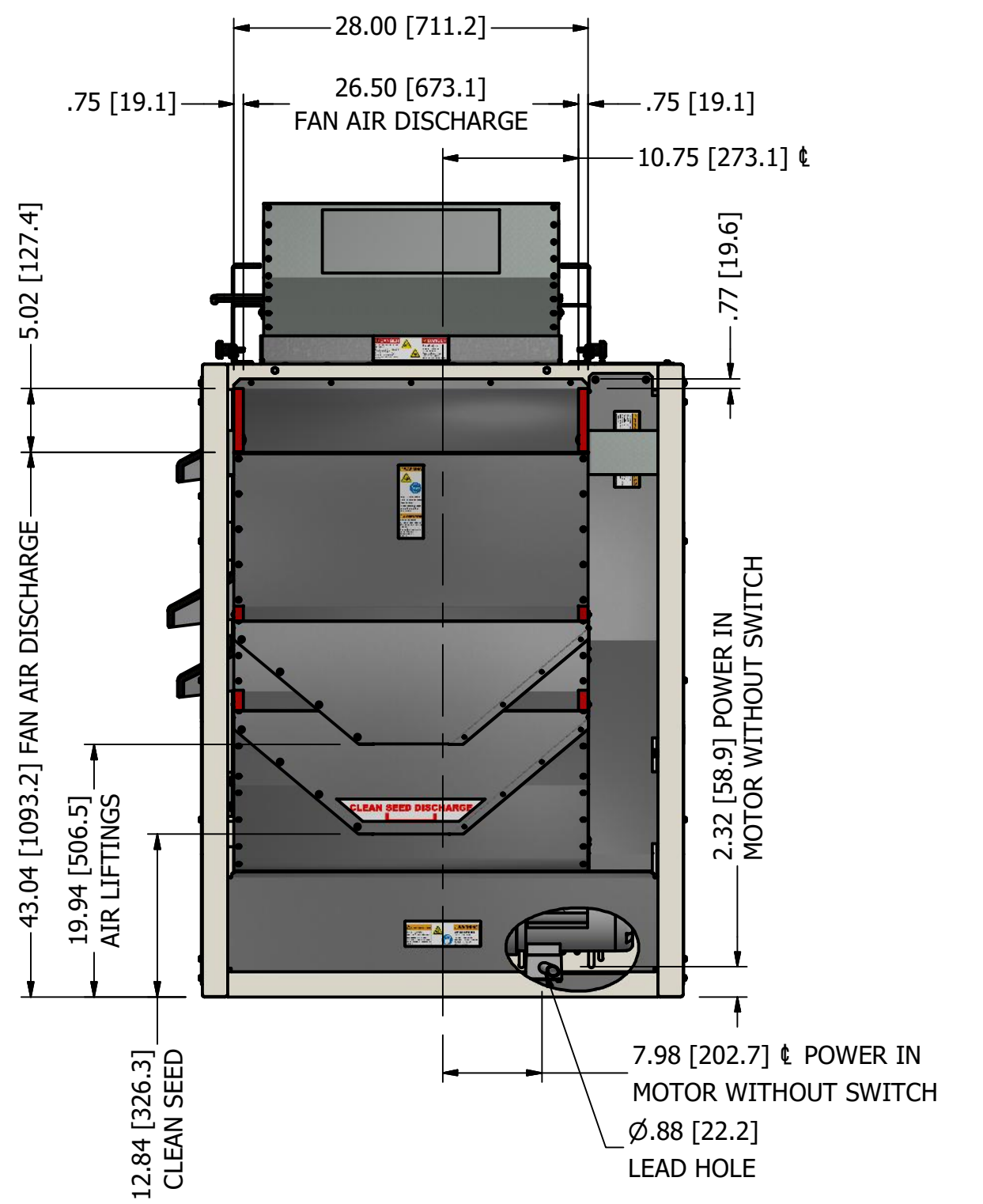

- NOTES:
- DO NOT SCALE FROM DRAWING.
  - ALTERNATIVE UNITS [X.X] IN MILLIMETERS.
  - MACHINE WEIGHT AS SHOWN: 750 LBS / 340 KG. SHIPPING WEIGHT AS SHOWN: 820 LBS / 372 KG.
  - 0.50" [12.7] TOTAL THROW, SHOE.
  - FAN AIR DISCHARGE: 1600 CFM / 45 CMM MAXIMUM.
  - FOUR 1/2-13 GRADE 5 BOLTS RECOMMENDED TO LAG FRAME THRU FLOOR JOISTS.
  - RECOMMENDED MAINTENANCE CLEARANCE FROM FRAME: 36.00" [915] AT FRONT & SIDES, 12.00" [305] AT REAR.
  - FUSED DISCONNECT REQUIRED PRIOR TO MACHINE MOUNTED SWITCH BOX.
  - MOTOR WITH SWITCH: 1 HP 1Ø 60 HZ 115/208/230 VOLT TEFC, MANUAL THERMAL RESET, FULL LOAD AMPS 13/6.8/6.5.1
  - MOTOR WITH SWITCH: 1 HP 1Ø 50 HZ 110/220 VOLT TEFC, MANUAL THERMAL RESET, FULL LOAD AMPS 12.8/6.4.
  - MOTOR WITHOUT SWITCH: 1 HP 1Ø 60 HZ 115/208-230 VOLT XPFC, U.L. & CSA APPROVED CLASS I, GROUP D, CLASS II, GROUP F & G, T4, FULL LOAD AMPS 11.8/6.3-5.9.
  - MOTOR WITHOUT SWITCH: 1 HP 3Ø 60 HZ 208-230/460 VOLT TEFC, FULL LOAD AMPS 3.1-3.0/1.5.
  - MOTOR WITHOUT SWITCH: 1 HP 3Ø 60 HZ 575 VOLT TEFC, FULL LOAD AMPS 1.5.
  - MOTOR WITHOUT SWITCH: 1 HP 3Ø 50 HZ 220/380/440 VOLT TEFC: AVAILABLE UPON REQUEST.
  - MOTOR WITHOUT SWITCH: 1 HP 3Ø 60 HZ 208-230/460 VOLT XPFC, U.L. & CSA APPROVED CLASS I, GROUP D, CLASS II, GROUP F & G, T4, FULL LOAD AMPS 3.9-3.6/1.8.
  - FRAME CONSTRUCTION: A500 GR. B STRUCTURAL CFS, PAINTED FINISH.

**BASE MACHINE**

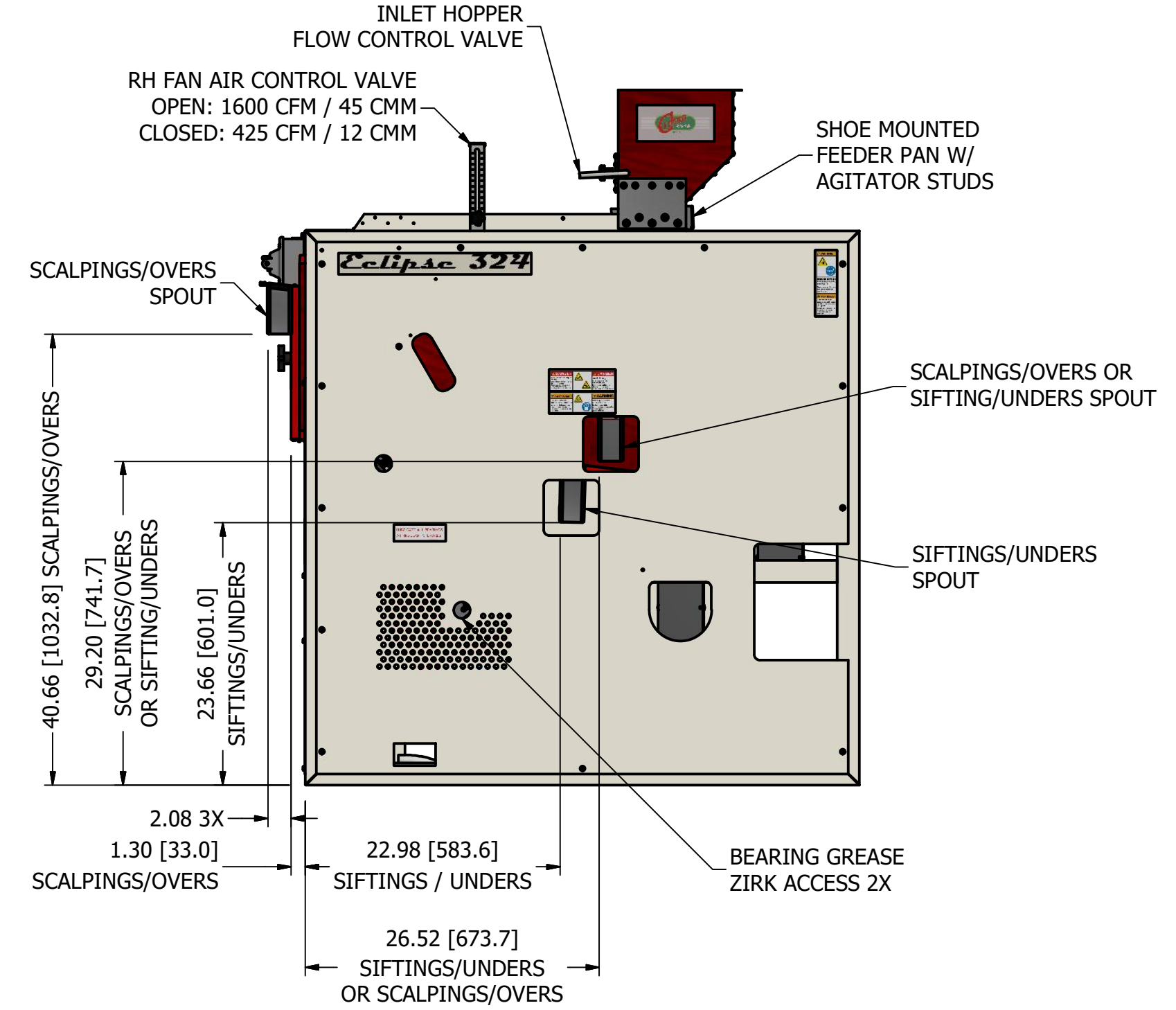
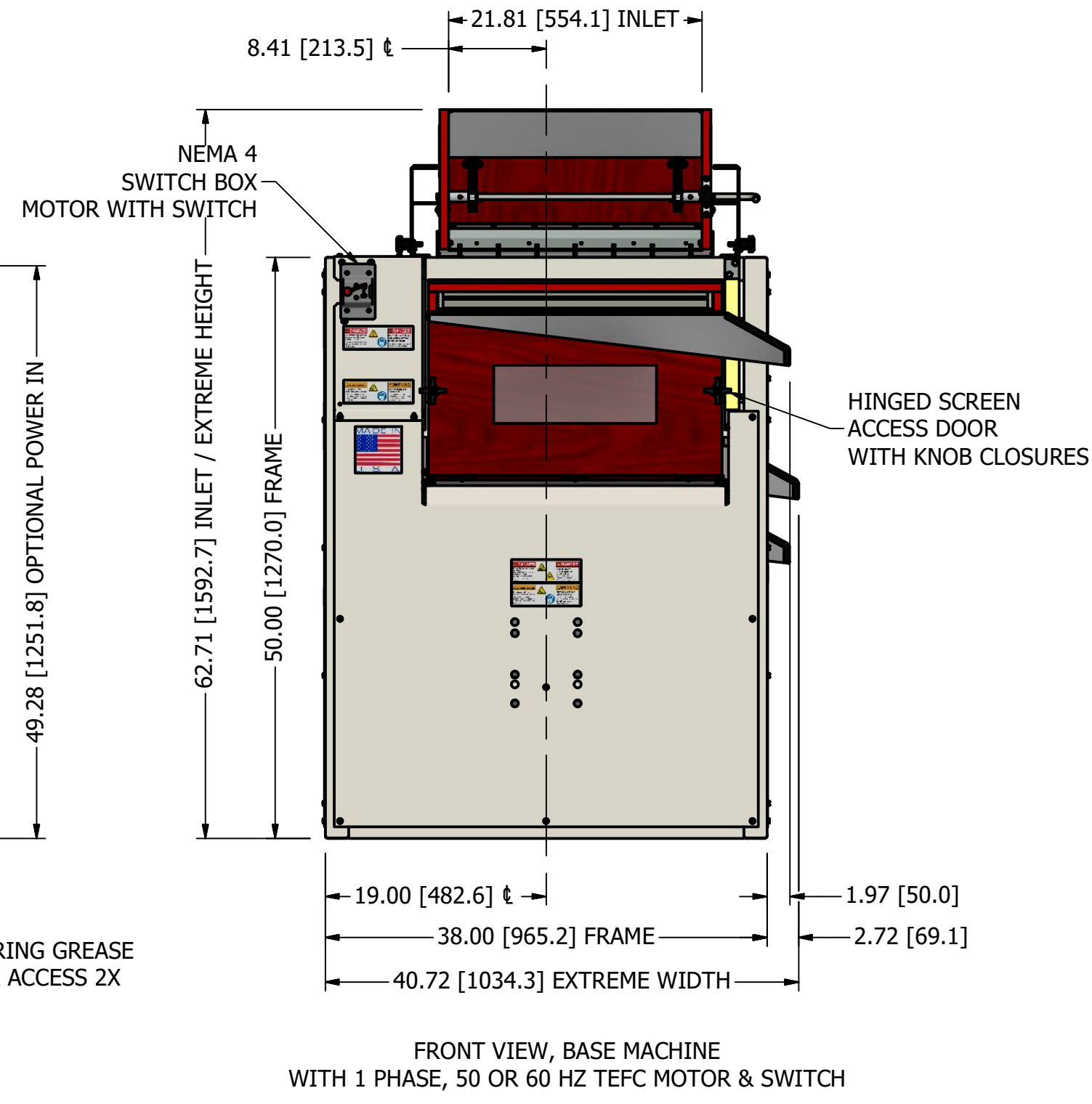
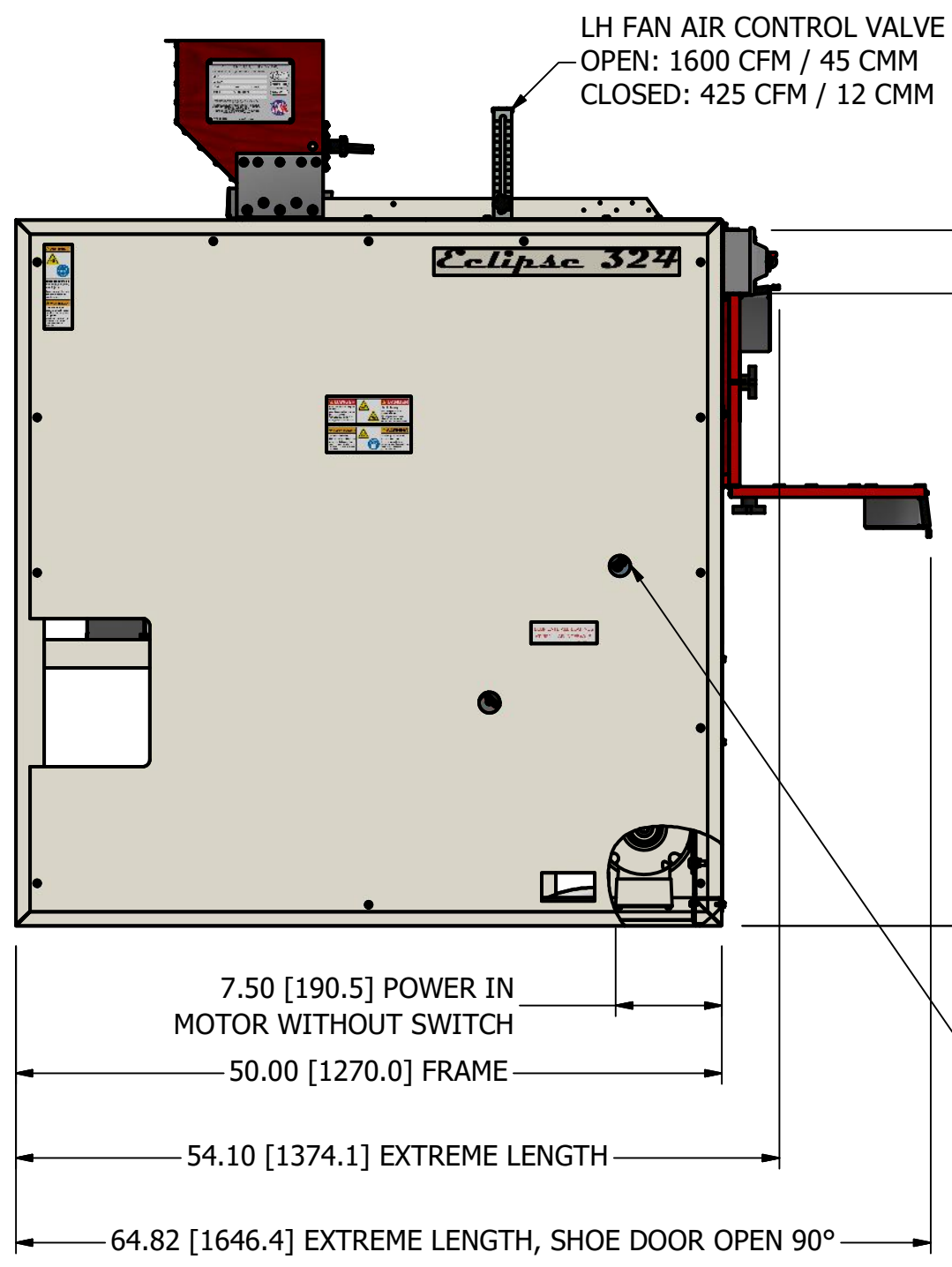
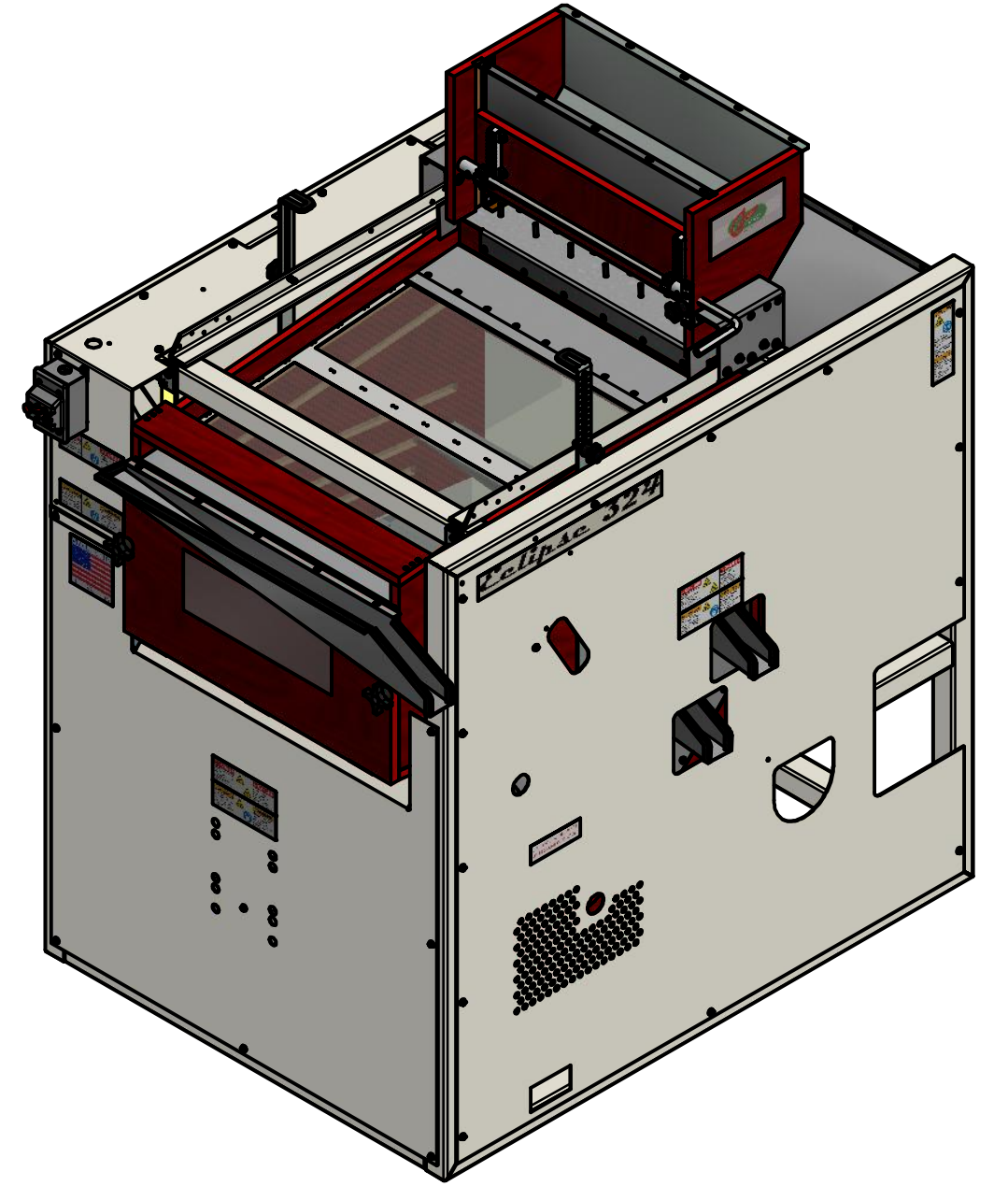
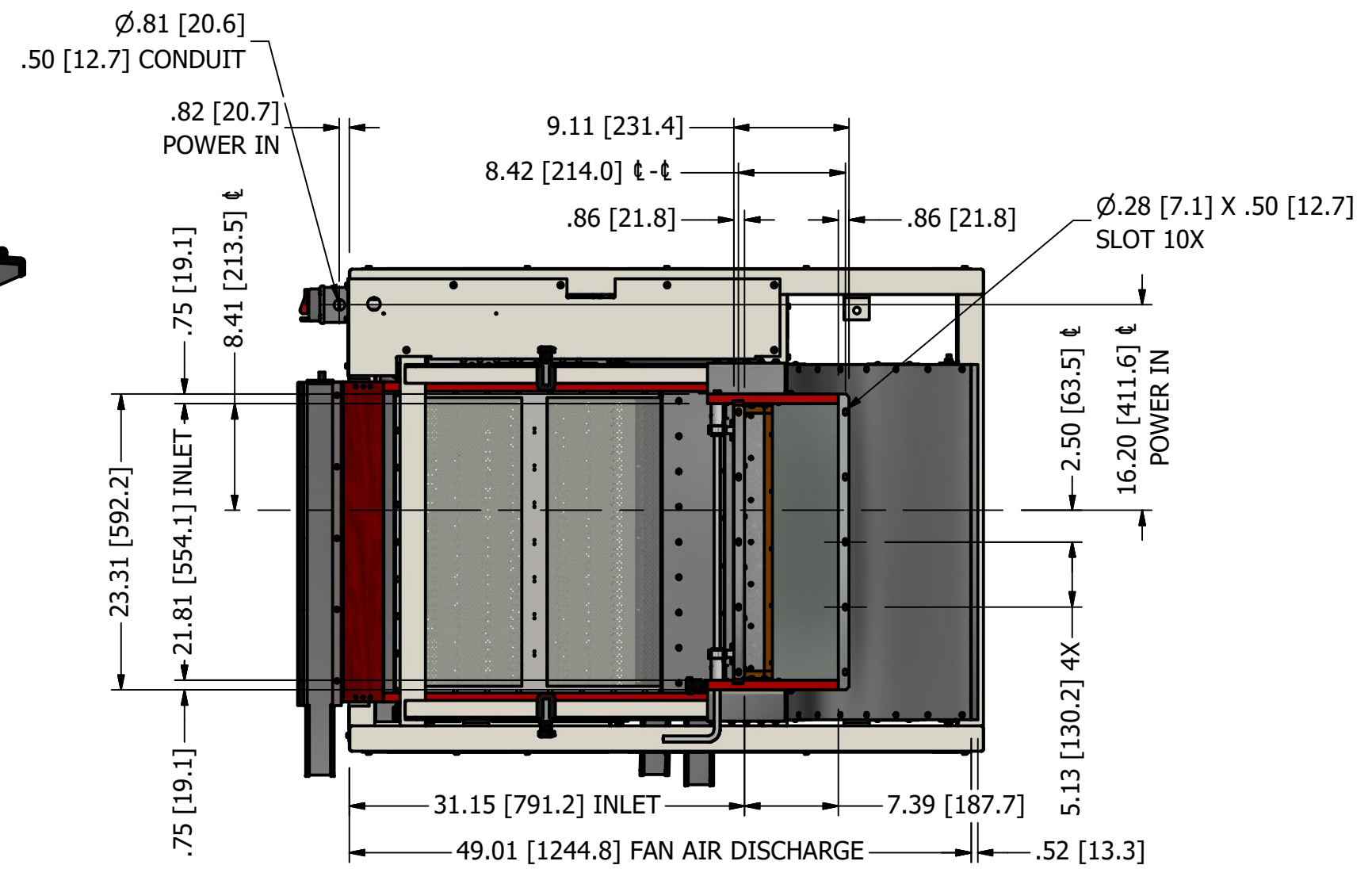
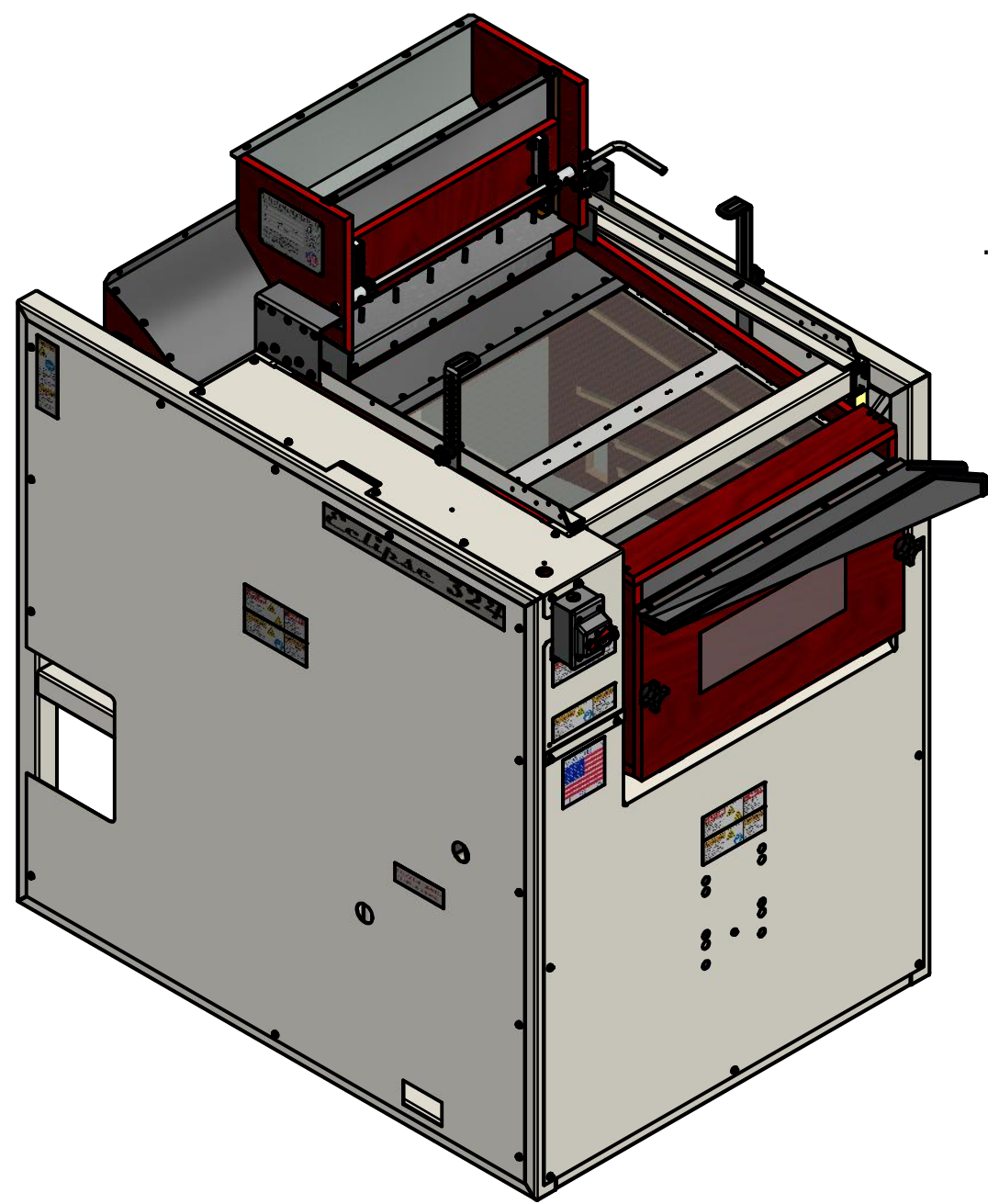
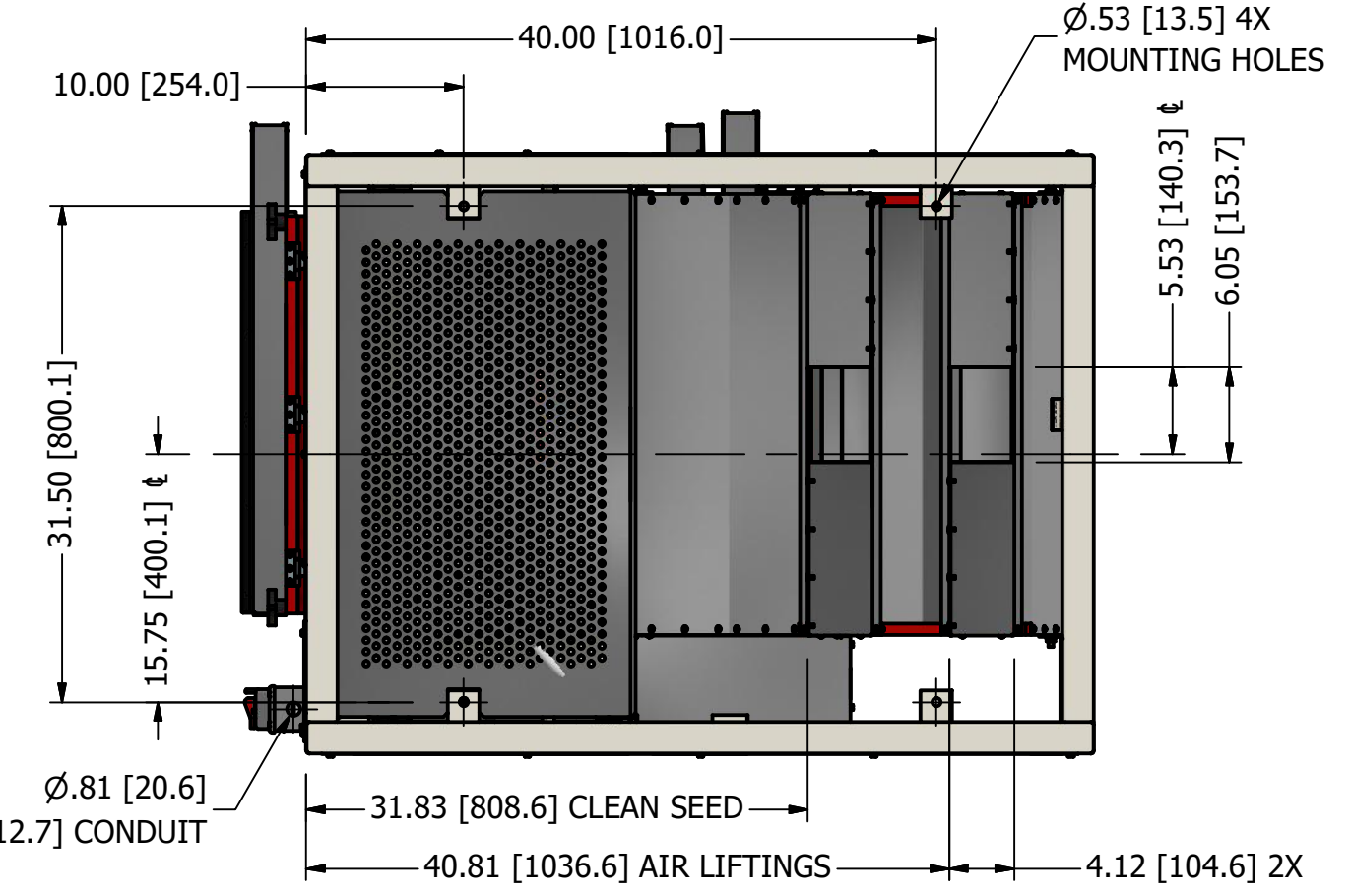

		DIVISION OF A.T.FERRELL COMPANY 1440 S ADAMS ST BLUFFTON, INDIANA 46714 - USA PH: 260-824-3400 FAX: 260-824-5463		This drawing is the property of the A.T. Ferrell Company, Inc and must be returned immediately upon request. No part of this drawing may be reproduced, stored in a retrieval system or transmitted in any form or by any means, without prior written consent of the A.T. Ferrell Company, Inc.	
TOLERANCES EXCEPT AS NOTED DECIMAL: ± .030 FRACTIONAL: ± 1/32 ANGULAR: ± 1/2°		TITLE: CLEANER ASSY, RH & CENTER, ECLIPSE 324		DRAWN BY: dmjohnson	
FINISH: TOUCH-UP PAINT		DRAWN DATE: 10/14/2011		APPROVED BY: DMJ	
CAD NO MANUAL CHANGES		SCALE: 1:10		SHEET: 1 OF 8	
SIZE: D		PART NUMBER: F6000000-1		REV: F	